



CARRYCOT / TOTE ADAPTER FOR ELEMENT™ STROLLER

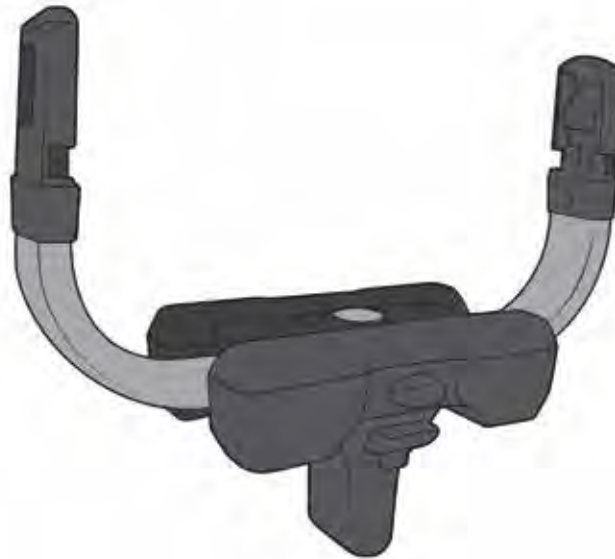
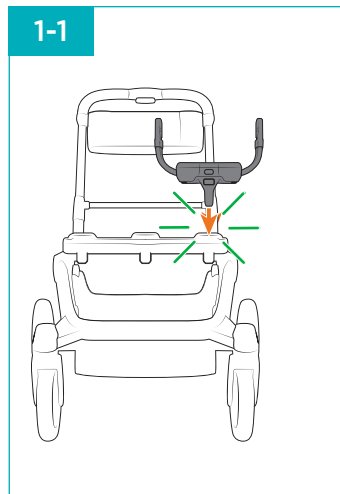
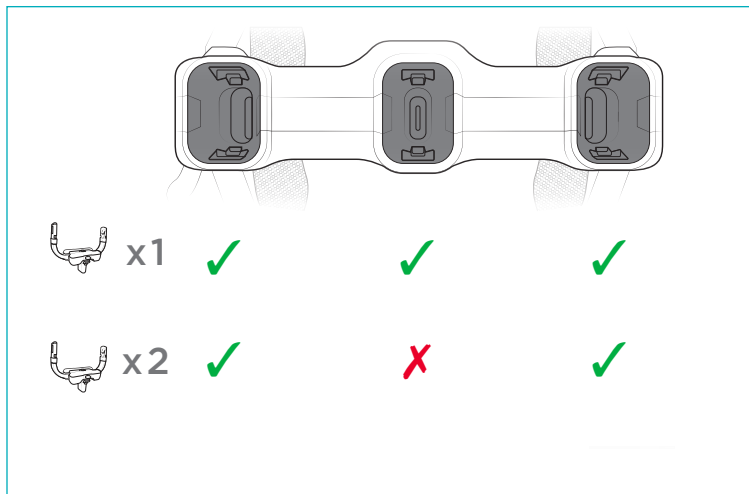

TABLE OF CONTENTS

Table of Contents 2	Table des matières 2	Índice 2	Inhaltsverzeichnis 2	Πίνακας περιεχομένων 2
1 Attach Accessory Adapter 2	1 Fixation de l'adaptateur auxiliaire 2	1 Fijar el adaptador de accesorios 2	1 Zubehöradapter anbringen 2	1 Τοποθέτηση προσαρμογέα αξεσουάρ 2
Remove Accessory Adapter 3	Retrait de l'adaptateur auxiliaire 3	Retirar el adaptador de accesorios 3	Zubehöradapter entfernen 3	Αφαίρεση προσαρμογέα αξεσουάρ 3
Possible Configurations 3	Configurations possibles 3	Configuraciones posibles 3	Mögliche Konfigurationen 3	Πιθανές ρυθμίσεις 3
Care & Maintenance 4	Entretien et nettoyage 5	Cuidado y mantenimiento 6	Pflege und Wartung 7	Φροντίδα και Συντήρηση 8
Limited Warranty 4	Garantie limitée. 5	Garantía limitada 6	Befristete Garantie 7	Περιορισμένη εγγύηση 8
Personal Record Card 4	Fiche de renseignements personnels 5	Tarjeta de registro personal 6	Persönliche Registrierkarte 7	Κάρτα προσωπικού ιστορικού 8

ATTACH ACCESSORY ADAPTER



TO REMOVE

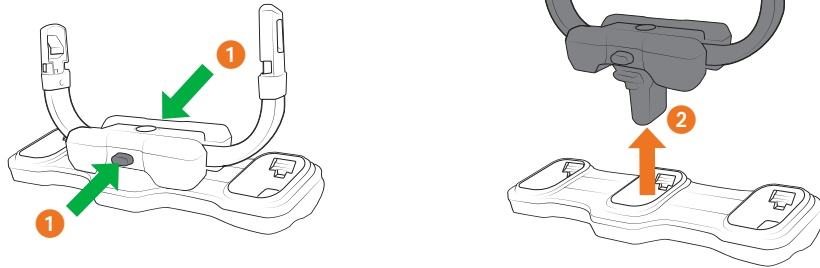

POSSIBLE CONFIGURATIONS

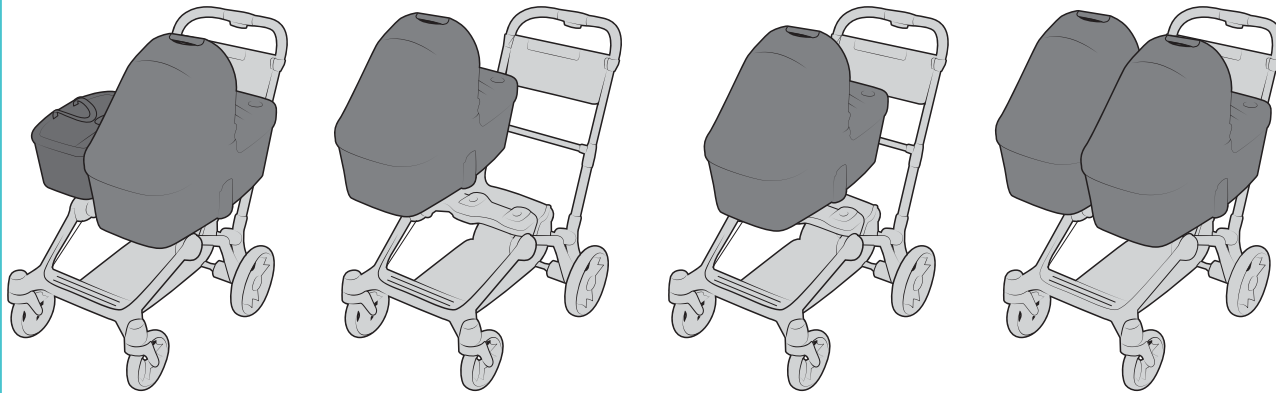

CARE & MAINTENANCE

- Clean metal parts with a damp cloth and wipe dry.
- If adapter becomes wet, wipe with a soft cloth to prevent rusting on metal frame.
- When storing stroller, never stack other items on top of or in it; this may damage the stroller.
- Periodically check for worn parts, loose screws, or torn materials and stitching.
- Replace any damaged parts immediately.

LIMITED WARRANTY

Contours® warrants this product to be free of defects in materials and workmanship, as follows: For a period of ONE YEAR from the date of purchase, Contours will repair or replace, at its option, the defective product. If you have a problem or are not satisfied with this product, please contact the Consumer Service Department at Contours.

REPAIR OR REPLACEMENT AS PROVIDED UNDER THIS WARRANTY IS THE EXCLUSIVE REMEDY OF THE CONSUMER. CONTOURS SHALL NOT BE LIABLE FOR ANY INCIDENTAL OR CONSEQUENTIAL DAMAGES FOR BREACH OF ANY EXPRESS OR IMPLIED WARRANTY ON THIS PRODUCT, EXCEPT TO THE EXTENT REQUIRED BY APPLICABLE LAW. ANY IMPLIED WARRANTY OF MERCHANTABILITY OR FITNESS FOR A PARTICULAR PURPOSE ON THIS PRODUCT IS LIMITED TO THE DURATION OF THIS WARRANTY.

Some states do not allow the exclusion or limitation of warranties set forth above, so the above exclusions may not apply to you. This warranty gives you specific legal rights, and you may also have other rights which vary from state to state. We sincerely thank you for your purchase of this Contours product.

To obtain warranty service, please call Contours Consumer Service Department at 1-888-226-4469 in U.S. and Canada, 1-312-361-6493 outside U.S. and Canada or contact us via email at customerservice@contoursbaby.com

If the product is returned to Contours Consumer Service Department for repair or replacement, it must be shipped prepaid and adequately insured.

For further information visit www.contoursbaby.com

Recall WEBSITE: HELP KEEP YOUR CHILD SAFE. Check www.recall.gov to see if any products you use with your child or any of your child's toys have been recalled.

PERSONAL RECORD CARD

Once in a while, we are less than perfect and one of our products with a problem reaches a customer. In most cases, we can solve your problem with replacement parts. Please contact us before you return one of our products to the store.

If you have a question about your product, please have the following available when you call:

- Product model number
- Date of manufacturing

You can find the Model Number and Date of Manufacture on a label located on the bottom of the adjustable mount. Having this information ready will expedite your service call.

Contours® - United States
1100 W Monroe St
Chicago, IL 60607

1-888-226-4469
customerservice@contoursbaby.com

Contours® - Europe
Windmolen 22
7609 NN Almelo
The Netherlands

+31 548 659096 / europe@contoursbaby.com

Model / Style Number: _____

Date of Manufacture: _____

Date of Purchase: _____